



## Four Junction Traffic Light Controller using PLC (S7-200)

Nyan Phyo Aung<sup>1</sup>, Mo Mo Myint Wai<sup>1</sup>, Lwin Lwin Htay<sup>1</sup>

<sup>1</sup> Department of Electronic Engineering, Technological University (Mandalay),  
Myanmar

Corresponding Author: Nyan Phyo Aung



### Article Info

#### Article history:

Received 13 October 2020

Received in revised form 22  
October 2020

Accepted 24 October 2020

#### Keywords:

traffic light

PLC

Micro Win and Four -way

Junction

### Abstract

Advance of a road traffic light control system using Programmable Logic Controller is the principal of the system. This system can be divided into two parts which are hardware and software. The hardware part for this system is a model of four -way junction of a traffic light. The Red, Yellow and Green are installed at each lane to represent as a traffic light signal indicator. This switches and lamps are linked to PLC. The PLC receives signal which is coming from the inputs (sensor and switch) and drives the units (lamps or relays). In the system, Siemens s7-200 PLC is used as the main controller of the traffic light system. The Step7 Micro Win software can be developed the ladder logic diagram which can control the traffic light for proposed system. So, the traffic light system can be successfully controlled by PLC.

## Introduction

One of the significant public facilities is the traffic light that plays an important role of the road users. Traffic signal light is used to control the movement of vehicles and passengers, so that traffic can flow smoothly and safely. Traffic signs are relatively simple and can be found in public area; they are critical for ensuring the protection of the driving zone. The increasing use of traffic lights indicates to their effectiveness in directing traffic flow, dropping the accidents and the most recently to their utility in controlling the flow of traffic through metropolitan areas which have been used together with computer systems. The typical traffic control system may be observed that the time of signal light glowing for a particular road will be always constant. Sometimes it may happen that, one particular road may be crowded more than any other.

The progress of a new traffic light system is controlled by PLC in this system. The is four-way traffic light model with turn way is introduced in this system. The main controller is PLC (Programmable Logic Controller) which is Siemens s7-200 with Simatic STEP 7-Micro/WIN. The PLC can control the traffic easy way.

## Literature Review

The first traffic light which is based on gas-lit without electricity was invented by the railway engineer, J. P. Knight Nottingham. it was installed outside the Houses of Parliament to prevent the traffic between Bridge Street and Parliament Street. This design has three semaphore arms with red and green gas lamps for night-time use, on a pillar, operated by a police constable. The length of signal is 22 feet. The gas lantern is controlled with a lever at is based by a police officer. The arm of the light, the semaphore, pointed to horizontal that means stop sign. The arm would lower to 45 degree means caution sign. the red and green light are used at night for stop and caution signs. Traffic lights are signaling devices positioned at road intersections.

Pedestrian crossings are today used in almost every city of the world. An American policeman invented the first electric traffic light. It has only two lights: red and green.(Eme et al., 2016).

Srivastava et al (2012) introduced the initial stages in the operation of a smart traffic light control system based on Programmable Logic Controller (PLC) technology. In this system, the goal of this model to measure the traffic density by counting the number of vehicles in each lane and their weight, then park in automated parking or diverge them accordingly. This is the problem of a traffic police to monitor the whole scenario round the clock. (Soh et al., 2010).

Cristian et al (2014). The control of an industrial process with PLC. In 2014 International Conference on Applied and Theoretical Electricity (ICATE) (pp. 1-4). IEEE. describes the road traffic system that is controlled by the PLC which takes the signals from different sensors on roads. The general road traffic system developed ensures the direction of four intersections, setting a path that respects coordination type green light the implementation of probes radar to inform traffic participants about recommended speed for accessing the green state located in the intersection that will follow to cross.

The author expressed that the new design of traffic light is a combination of ARM LPC 2148 with GPS as a control unit and CC2500 RF module. The traffic jam can cause during the long red-light time interval in a typical traffic light system (Li et al., 2009). This traffic control system offers multiple traffic light control and monitoring system that reduce the possibilities of traffic jams.

Roxanne Hawi et al (2015) expressed other solutions to traffic congestion because of insufficient space and funds for the construction of new roads. The author describes traffic routing decisions that can calculate by using smart traffic control systems (STCS). These systems use real time data and try to prove promising in vehicle traffic control and management. This paper points out the motivations behind the emergence of STCS and the different types of these systems in use today for road traffic management. (Downs, 1962).

Nikhil R. Chitragar et...al; Traffic signals are the most suitable method of controlling traffic in rush hour. The author present traffic signals that fail to control the traffic effectively when a particular lane has got more traffic than the other lanes. The intelligent or “Smart Traffic Control” is one which would be able to calculate the vehicle density in a lane at 4-way junctions and then decide the priority automatically using a program

### ***The Proposed Model of Traffic Light Control System***

The proposed four-way traffic light model layout is as shown in figure 1. And the block diagram of the proposed four-way traffic light model is as shown in figure 2. The system has new feature which was turn way pass or not. The PLC acts as the main controller of the system. Siemens S7-200 PLC model is used in this system.

### ***Implementation Of The Proposed System***

In this proposed system, there is two portions: hardware and software. The main hardware components are PLC (programmable logic controller) which acts as main controller of system. And the software is required to write PLC ladder diagram. Siemens step 7 MicroWin software is used to ladder programming and downloading the PLC.

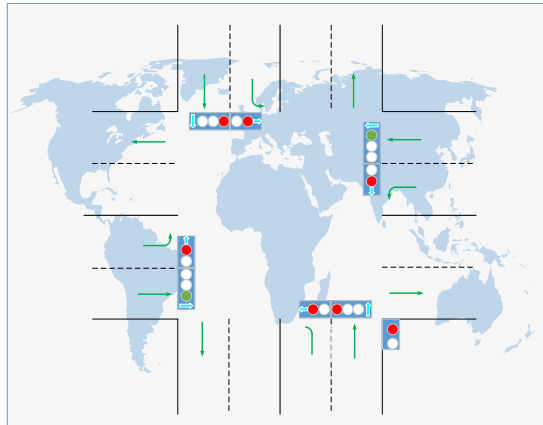


Figure 1. Four Way Traffic Light Model Layout

The programmable logic controller (PLC) is an industrial computer that can control and automate complex processes. Programmable logic controllers are a relatively recent development in industrial automation. It has designed for use in an industrial environment, which has the integral storage of user-oriented instructions such as logic, sequencing, timing, counting, and arithmetic function. It can control and monitor digital or analog inputs and outputs, various types of machines or processes.

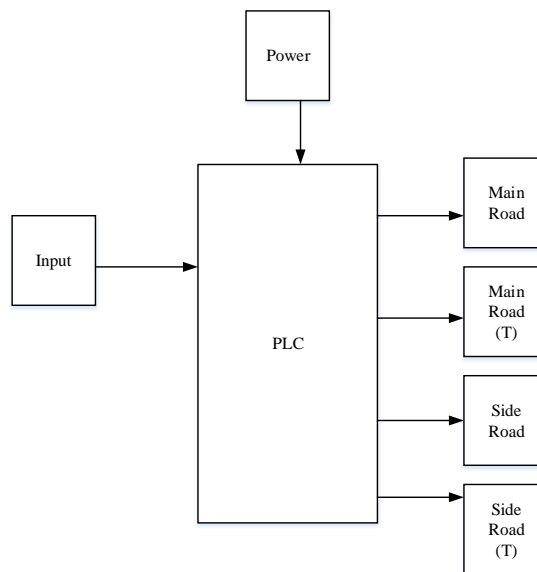


Figure 2. The block diagram of four-way traffic light with turn way

PLC is used to monitor input signals from a variety of input points (input sensors) and report events and conditions occurring in a controlled process. PLCs are used to control robots, assembly lines, and various other applications that require a large amount of data monitoring and control. A typical programmable logic controller employs a backplane to serve as the transport network bus for communicating the PLC with input/output devices. The input/output card of PLC can be placed within the rack. PLC's are normally made in modular fashion to allow them to be easily reconfigured to meet the demands of the particular process being controlled. The processor and I/O circuitry are normally constructed as separate modules that may be inserted in a frame and connected together through a common backplane using permanent or releasable electrical connectors. The basic system model of PLC is as shown in figure 3.

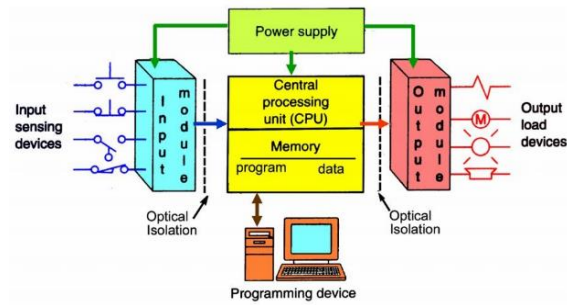


Figure 3. The Basic Model of PLC (Source: Electrical A2Z, 2016)

### Siemens PLC S7-200

The Siemens S7-200 PLC is a very useful PLC. It is the cheapest and very easy to begin programming of the product of Siemens PLC. The Siemens S7-200 has some limitation in functions, but it certainly also has a lot of advantages. The Figure 4 shows the **Siemens PLC s7-200 (cpu224xp)**.

The smallest PLC model of Siemens is **S7-200**. Even though the S7-200 PLC system is still the cheapest, it is now the latest series of Siemens PLC's. Siemens has made a new tool for learning PLC programming. this **S7-200** PLC has some clear advantages over other cheap PLC's.

- Relatively cheap PLC
- Easy to program for beginners
- Build on the Siemens platform

The Siemens CPU 224xp PLC is as shown in figure 4. It is DC/DC/DC type PLC.



Figure 4. S7-200 CPU 224xp PLC

### Power Supply

As the PLC based system, the main supply unit of the system uses 24 DC power supply because it is the industrial standard. The 24-v dc switching mode power supply is used in the system as shown in figure 5.



Figure 5. The switching Mode power supply for system

The schematic diagram of system is settled from proposed system block diagram. The schematic diagram of the system is as shown in figure 6. From this figure, the PLC requires dc 24 v. And it is supported by switching 24 power supply. The start and stop buttons are connected in input of the PLC and pilots' light. Main road and side road, are output of PLC.

When the start button is pressed, the PLC run the traffic light program which are written by algorithm. The green of main road pilot lam is on. During that time the side road of red led is on. That is about 4 second. The green light is changed into yellow by 2 sec. After 2sec, the main road is turn into red light. Whereas the side road is turn into green. That is the loop until stop button is pressed. After the side road green light is off, the turn is on.

In this research, the main hardware of the traffic light control system is Siemens S7-200 PLC. This is easy programming with STEP 7-Micro/WIN software. The CPU model of s7-200 model is CPU224xp. By referring from the figure 6, the wiring connection of PLC and traffic light of lamps are denoted as table 1. It describes about the PLC address of input and output wiring connection of lamp. As the four-way traffic light system, the system has the main and side road junction. The main has 5 pilot lamps and side road has the same amount of light. The lamp of main and side road of wiring connection are as shown in figure 6.

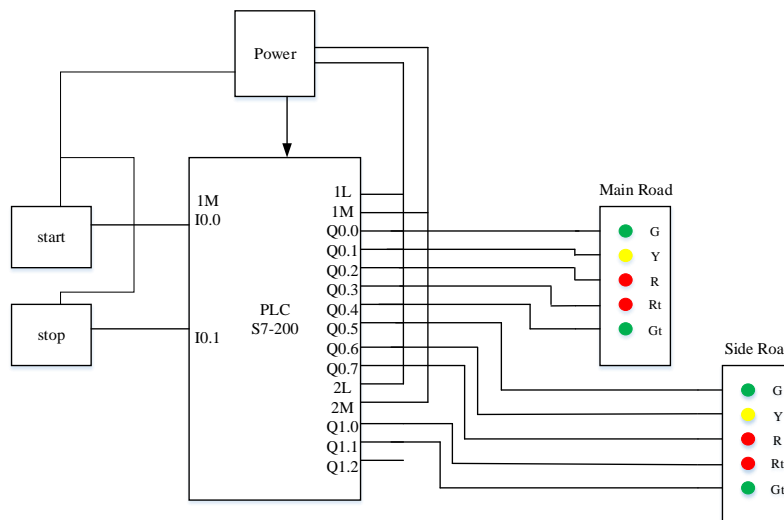


Figure 6. The Schematic Diagram of Traffic light for four way

### Software Implementation of the System

The main hardware component of the system is the PLC which is S7-200 Siemens PLC. The STEP 7-Micro/WIN can support S7-200 Siemens PLC can program using STEP 7-Micro/WIN software. It supports standards programming languages such as:

- Ladder Logic (LAD)
- Function Block Diagram (FBD)
- Instruction List (IL) in Siemens PLC's called Statement List (STL)

When the program is started, main road is green and the side road is red about 15s. After this, the yellow light is turn on 5s. And the side road is green and main road is red about 15s. After side is yellow about 5s, it changes to red. At that time the main road turn is green and side road turn is red about 10s. After 10s, the side road is green and the main road is green. This is depicted as the flow chart and as shown in figure 7. The flow chart of the operation of the system is developed.

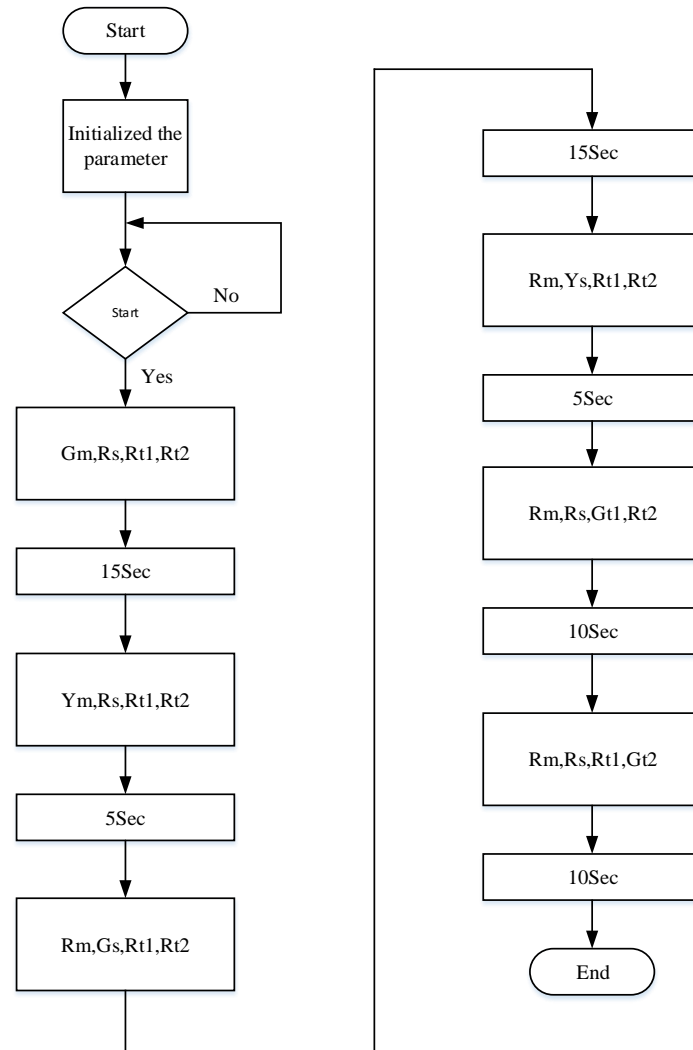


Figure 7 The Flow Chart of Operation of Traffic Light System

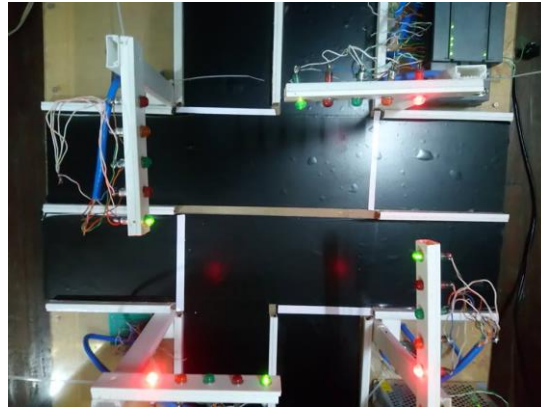
Table 1. The Label of Traffic Light

Lamp	PLC	
	Main Road	Side Road
Green	Gm	Gs
yellow	Ym	Ys
Red	Rm	Rs
GT	Gt1	Gt2
RT	Rt1	Rt2

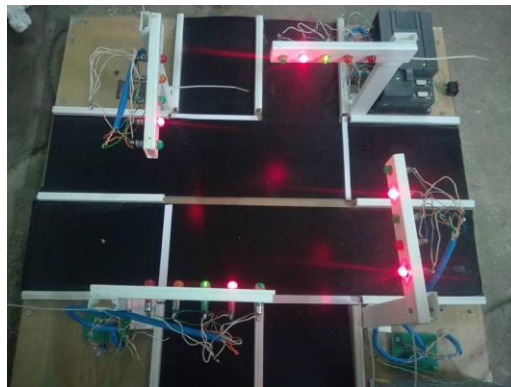
### Results and Discussion

The PLC and other component of the system are constructed to together to form the traffic light system. The figure 8 shows the complete system of traffic light system. The system has PLC (S7-1200), power supply and lamp. The main road lamps are connected and the side road lamps are connected together. The main road has red, yellow, green, turn green and turn red. The side road has also the same. The side road is red and the main road is green as shown in figure 9. After 15 second, the side road is red but the main road yellow light is turn on.

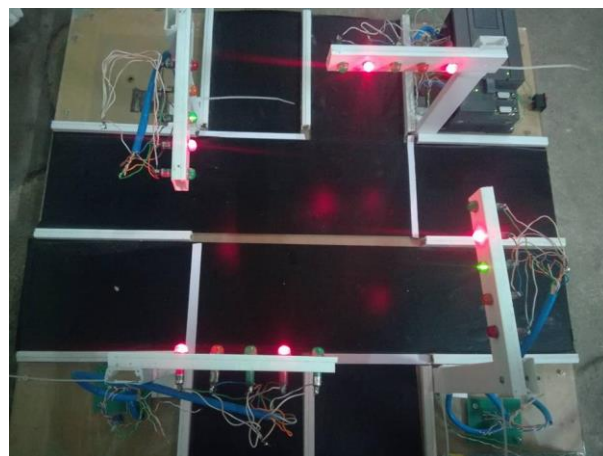
When the main road is red, the side road is green. After the 15second, the green lamp of the side road is turn off and change into the yellow as shown in figure 11. From the experimental result, the PLC based traffic control system is suitable for the real application. This chapter expresses the testing of the hardware of the PLC based traffic light system.



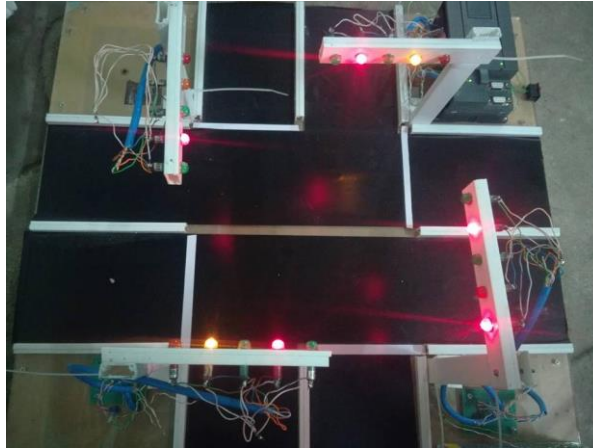
*Figure 8 The Complete The Hardware System of The Traffic Light*



*Figure 9. The Main Road is Green and Side Road is red, All Turn are OFF*

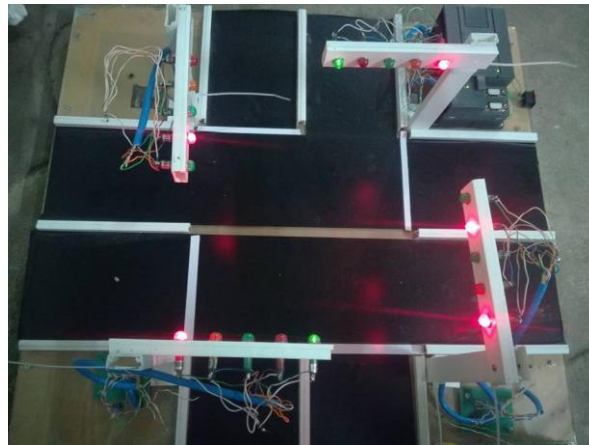


*Figure 10. The Main Road is Red and Side Road is Green, All Turn are OFF*



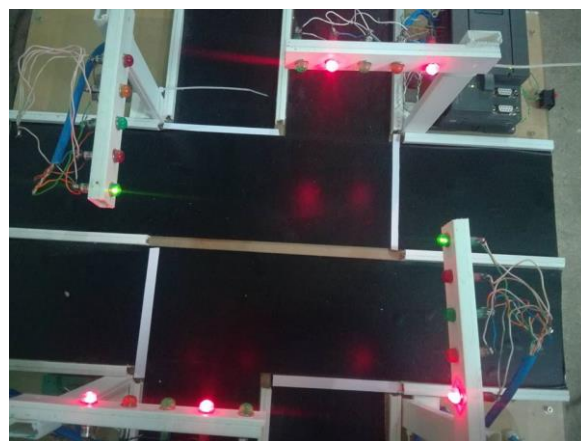
*Figure 11. The Main Road is Yellow and Side Road is Red, All Turn are OFF*

After the main road and side road are red, the main turn is green and the side turn is red as shown in figure 12.



*Figure 12. The Main Road is red and Side Road is Red, the main turn is green and side turn is red*

After 5s green of the main turn on, it goes to red. And the side turn is green. In figure 13, the side turn is green.



*Figure 13. The Main Road is red and Side Road is Red, the main turn is green and side turn is red*

## Conclusion

This system can reduce congestion on roads and would help in coping with accidents as the heavy vehicles and light vehicles will be in different lanes. The serious problem of traffic congestion and fatal accidents can decrease using this system. Thus, the proposed system would make our roads a safer place to travel. The PLC based traffic light system had successfully been designed and developed. This prototype can easily be implemented in real life situations. Increasing the number of sensors to detect the presence of vehicles can further enhance the design of the traffic light system. Another room of improvement is to have the infrared sensors replaced with an imaging system/ camera system so that it has a wide range of detection capabilities, which can be enhanced and ventured into a perfect traffic system.

## Acknowledgment

The author would like to mention his thanks to Mo Mo Myint Wai, Lwin Lwin Htay, Siemens Myanmar, Han Zaw Myint and all his partners from EcE Dept, TU(Mdy) for their supports.

## References

- Cristian, B., Constantin, O., Zoltan, E., Adina, P. V., & Florica, P. (2014). The control of an industrial process with PLC. In *2014 International Conference on Applied and Theoretical Electricity (ICATE)* (pp. 1-4). IEEE.
- Downs, A. (1962). The law of peak-hour expressway congestion. *Traffic Quarterly*, *16*(3).
- Electrical A2Z. (2016). *PLC Programmable Logic Controller Hardware Components / PLC Hardware Basics*. Available from: <http://electricala2z.com/motors-control/plc-programmable-logic-controller-hardware-components-plc-hardware-basics/>
- Eme, O., Federal, A. I., Idemudia, J. O., & Udo, A. (2016). Simulation of N-Way Traffic Lights Using Arduino Uno Environment. *International Journal of Computer Applications Technology and Research*, *5*(8), 543-550.
- Hawi, R., Okeyo, G., & Kimwele, M. (2015). Techniques for Smart Traffic Control: An In-depth. *International Journal of Computer Applications Technology and Research*, *4*(7), 566-573.
- Khattak, M. A. (2011). PLC based intelligent traffic control system. *International Journal of Electrical & Computer Sciences IJECS-IJENS*, *11*(06).
- Li, X., Shu, W., Li, M., Huang, H. Y., Luo, P. E., & Wu, M. Y. (2008). Performance evaluation of vehicle-based mobile sensor networks for traffic monitoring. *IEEE transactions on vehicular technology*, *58*(4), 1647-1653.
- Soh, A. C., Rhung, L. G., & Sarkan, H. M. (2010). MATLAB simulation of fuzzy traffic controller for multilane isolated intersection. *International Journal on Computer Science and Engineering*, *2*(4), 924-933.
- Srivastava, M. D., Prerna, S. S., Sharma, S., & Tyagi, U. (2012). Smart traffic control system using PLC and SCADA. *International Journal of Innovative Research in Science, Engineering and Technology*, *1*(2), 169-172.